



北奕机械
BeiYi Machinery

wuxi beiyi excavator parts factory

Add. District A ,Shuangmiao industry Park,Luoshe Town,Huishan District,Wuxi

Web.www.wxbychina.com



北奕机械
BeiYi Machinery

HYDRAULIC BREAKER OPERATION MANUAL



Address:
Shuangmiao Industry ParkA, Luoshe Town, Huishan
District, Wuxi.
Email: beiyipiling@163.com
Tel: +86 85450099
Website: www.wxbychina.com

1. Safety Precautions

- **This manual contains safety, operation, and routine maintenance instructions. It does not contain assembly and disassembly service procedure instructions. If needed, complete disassembly and assembly instruction are contained in the service manual which can be ordered from your Hydraulic breaker authorized and certified dealer.**
- **Please read the following warning.**



DANGER

SERIOUS INJURY OR DEATH COULD RESULT FROM THE IMPROPER REPAIR OR SERVICE OF THIS BREAKER. REPAIRS AND / OR SERVICE TO THIS BREAKER MUST ONLY BE DONE BY AN AUTHORIZED AND CERTIFIED DEALER.

General safety precautions

- **The hydraulic Breaker series BYD type will provide safe and dependable service if operated in accordance with the instructions given in this manual. Read and understand this manual any decals and tags attached to the breaker before operation. Failure to do so could result in personal injury or equipment damage.**
- Operate the breaker in accordance with all laws and regulations which affect you, your equipment, and the work site.
- Do not operate the breaker until you have read the carrier equipment manual and thoroughly understand all safety requirement, operation and maintenance instructions.
- Ensure that all maintenance procedures recommended in this manual are completed before using the equipment.
- The operator must not operate the breaker or carrier if any person is found within the danger zone where they may be injured by flying debris or movement of the equipment.
- Know the limitation of your equipment.
- Establish a training program for all operators to ensure safe operation.
- Do not operate the breaker unless thoroughly trained or under the supervision of an instructor.
- Get used to the carrier controls before operating the carrier and the breaker.
- While learning about the breaker and the carrier, please do so at a slow pace. If necessary, set the carrier mode selector to the slow working position.
- Make sure all control (levers and pedals) are in the neutral position before starting the carrier.

- Before leaving the carrier, always lower the boom and insure the carrier is stable. Never leave the machine when the engine is running. Always engage the parking breaker locked.
- Stop the engine before attempting to make any repairs, adjustments, or servicing to either the carrier or the breaker.
- Do not operate the breaker at oil temperature above 175°F/80°C. Operation at higher temperatures can damage the internal components of the breaker and as well as backhoe/excavator, and will result in low breaker performance.
- Do not operate the breaker at in the severe conditions, such as, a damage, leaking, improperly adjusted, or incompletely assembled breaker.
- Do not modify breaker tool in any manner.
- Use only breaker and breaker tools manufactured by BEIYI only. Using the breaker tool produced by other manufacturers may damage the equipment and will void the warranty.
- To avoid personal injury or equipment damage, all breaker repair, maintenance and service must only be performed by authorized and properly trained personnel.
- If you do not understand how to operate your breaker, contact an authorized BEIYI Dealer for assistance.
- Keep this manual with the breaker.
- Do not operate this equipment if you are taking medication which may affect you mental judgment or physical performance.
- Do not operate this equipment if you are under the influence of drugs or alcohol.
- Remove breaker from carrier during the transport.

● **Warning sticker**

- shown smaller than actual size



Use Hearing Protection



Use Eye Protection





Use Breathing Protection



Read the manual before use

● **Safety symbols**

 DANGER
<p>This safety symbol may appear on the breaker. It is used to alert the operator of an action that could place him/her or other in a life threatening situation.</p>

 WARNING
<p>This safety symbol appears in these instructions to identify an action that could cause bodily injury to the operator or other personnel.</p>

IMPORATNT
<p>This safety symbol appears in these instructions to identify an action or condition that could result in damage to the breaker or other equipment.</p>

- Safety symbols are to emphasize all operator, maintenance, and repair action, which, if not strictly followed, could result in a life-threatening situation, bodily injury or damage to equipment.
- Always observe safety symbols. They are symbols for your safety and for the protection of the tool.
- **Greasing sticker**

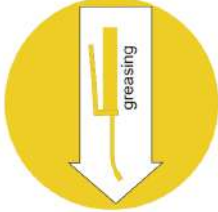
GREASING	
	<ol style="list-style-type: none"> 1. With breaker mounted on carrier, apply down pressure on tool. 2. Fill cavity with recommended grease. 3. Grease whenever tool looks dry. 4. When installing a new tool, liberally coat the upper 1/3 of the tool with grease before inserting. 5. Failure to comply with these instruction can result in damage To the breaker and will void the warranty.

2 Technical Specification

区分		单位	BYD68	BYD75	BYD100	BYD135	BYD140	BYD155	BYD165	BYD175	
			Powercell Weight	With Chisel	Kg	151	208	471	759	911	1283
		Lb	333	459	1038	1673	2008	2829	3181	4242	
Total Weight	Side /Box type	Kg	250/279	380	765/847	1462	1740	2413	2650	3788	
		Lb	551/615	838	1687/1868	3223	3836	5320	5842	8351	
	Top	Frame	Kg	298	375	-	1675	1861	2838	3065	4002
			Lb	657	827	-	3692	4103	6257	6757	8824
	Top	Kg	292	370	890	1544	1830	2781	2996	3833	
		Lb	644	815	1962	3404	4035	6131	6605	8450	
Total Length	Side /Box type	mm	1349/1421	1618	1934/2089	2295	2429	2776	2953	3176	
		in	53.1/55.9	63.7	76.1/82.2	90.4	95.6	109.3	116.3	125.0	
	Top	Frame	mm	1616	1849	-	2729	2896	3290	3470	3739
			in	63.6	72.8	-	107.4	114.0	129.5	136.6	147.2
	Top	mm	1602	1869	2358	2691	2818	3215	3392	3734	
		in	63.1	73.6	92.8	105.9	110	126.6	133.5	147.0	
Full Width	Side /Box type	mm	270/307	315	408/410	508	508	610	630	665	
		in	10.6/12.1	12.4	16.1/16.1	20.0	20.0	24.0	24.8	26.2	
	Top	Frame	mm	326	339	-	620	620	710	710	760
			in	12.8	13.3	-	24.4	24.4	28.0	28.0	29.9
	Top	mm	350	336	438	550	620	720	720	720	
		in	13.8	13.2	17.2	21.7	24.4	28.3	28.3	28.3	
Required Oil Flow		ℓ/min	40~70	50~90	80~110	100~150	120~180	180~240	200~260	210~290	
		gal/min	10.6~18.5	13.2~23.8	21.1~29.1	26.4~39.6	31.7~47.6	47.6~63.4	50.8~68.7	55.5~76.6	
Operating pressure		kg/cm ²	110~140	120~150	150~170	160~180	160~180	160~180	160~180	160~180	
		psi	1565~1991	1707~2134	2134~2418	2276~2560	2276~2560	2276~2560	2276~2560	2276~2560	
Impact Rate		BPM	500~900	400~800	350~700	350~600	350~500	300~450	250~400	200~350	
Hose Diameter		in	1/2	1/2	3/4	1	1	1 1/4	1 1/4	1 1/4	
Tool Diameter		mm	68	75	100	135	140	155	165	175	
		in	2.7	3.0	3.9	5.3	5.5	6.1	6.5	6.9	
Applicable Excavator		m ³	0.15~0.3	0.2~0.35	0.4~0.6	0.6~0.8	0.7~0.9	1.1~1.4	1.2~1.7	1.4~2.0	
		ton	4.0~7.0	6~9	11~16	16~21	18~26	28~35	30~45	40~55	

and features in catalogue are subject to change without prior notice to better improvement in quality.

3. Construction and Main Parts (Inward Valve Type)

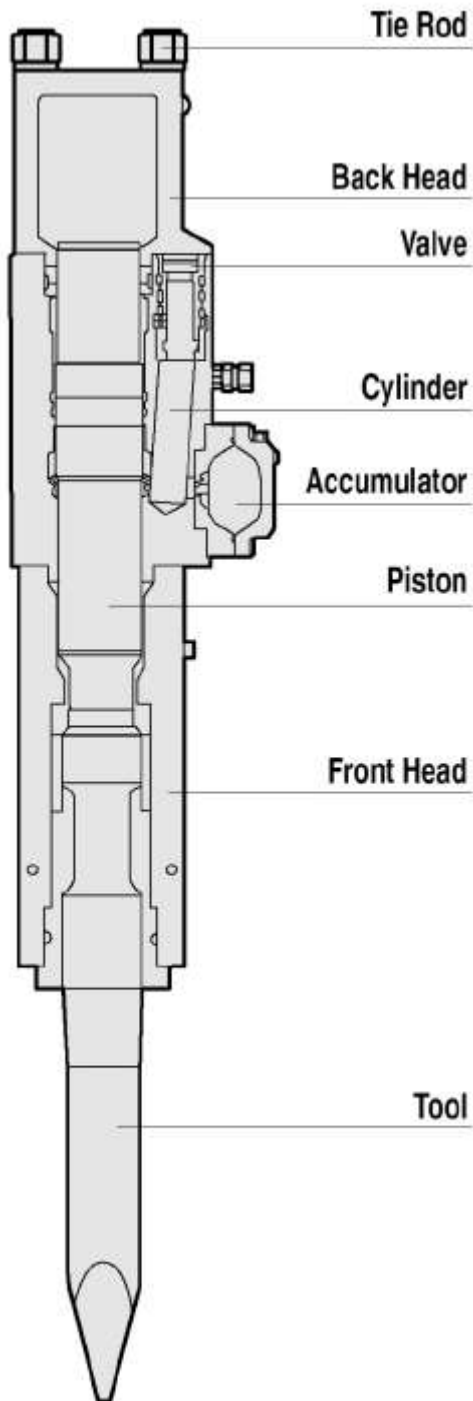

- **Tie Rod**
Front head, cylinder, and back head of breaker Body are tightly fixed with four tie rods.
- **Back Head**
Oil pressure inlet and outlet ports and Gas charging valve are built in it, and the inside is charged with N₂-gas.
- **Valve**
Cylindrical control valve is built in the valve housing to control piston reciprocation.
- **Cylinder**
The cylinder is the heart of the breaker containing hydraulic circuit for piston reciprocation.
- **Piston**
Kinetic energy of the piston is converted into blowing energy after hitting the tool. The blowing energy is transmitted to the tool to break rocks.
- **Front Head**
The front head supports the whole breaker components. upper bushing prevents shock from the tool.
- **Tool**
The specially heat-treated tool is directly applied to break rocks. It is used as moil point, wedge point, and flat tool according to the application, (optional)
- **Accumulator**
The accumulator compensates the pressure in the hydraulic circuit and prevents pulsation. It is not usually necessary to refill. Use N₂-gas only. (In main body)

The relation between the area [A1] affecting the pressure from the upper chamber of the piston and the [A2] affecting the pressure from the lower chamber of the piston is $A1 > A2$ and high pressure always applies to A2. When A1 change from high to low pressure or vice versa, Piston C2 reciprocates. Inside of back head is changed with the high pressure gas and gas energy stored in the up stroke of the C2 effectively acts on the piston C2 during the impact.

1. POWER

When piston C2 reaches top head center, high pressure oil from valve high-pressure port B3 applies to upper chamber of the piston A1 to change the piston stroke from upstroke to impact. At this time the relation between the area(A3) affecting the pressure from valve high pressure changes and the area(A4) of the valve change chamber is $A4 > A3$. The high pressure always applies to A4 and valve C4 remains in the upper position.

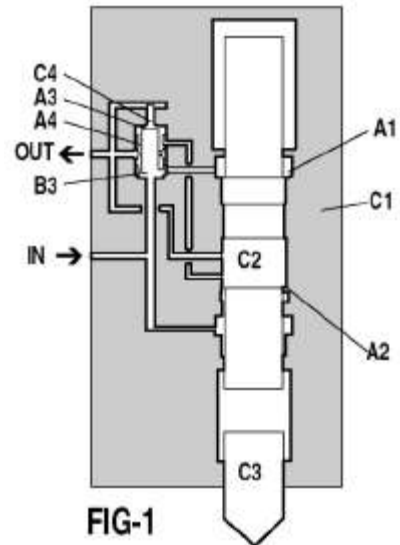

2. VALVE SHIFT

When cylinder low pressure port B1 is connected to cylinder change port B2, the pressure in valve change port B4 lowers. As force acting port C4 is the only pressure in valve high pressure chamber A3, valve C4 starts lowering. During the valve lowering stroke, valve high pressure port B3 is closed and valve low pressure port B5 is opened to the lower the pressure in the upper chamber of the position A1.

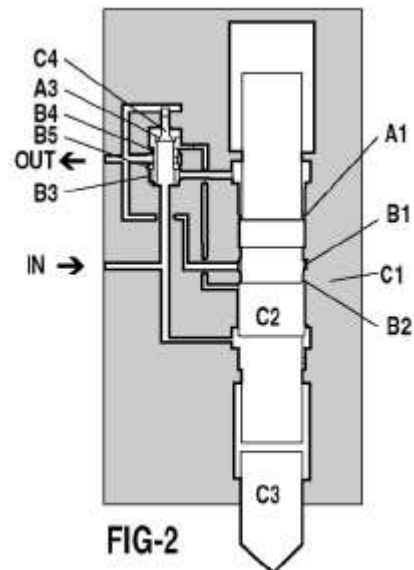

3. IMPACT

When piston C2 reaches impact point, kinetic energy obtained by piston C2 during the impact stroke is transmitted to the tool C3 for the impact energy required to break. At this time, as high pressure applies only to the lower chamber of the piston A2, piston C2 starts reversing. Further, as high pressure applies only to the valve high pressure chamber A3, valve C4 is remaining in the lower position.

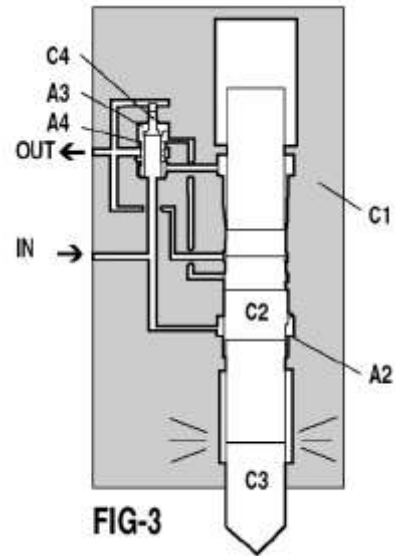

4. UPSTROKE

When cylinder change port B2 is connected to cylinder lower pressure port B1, high pressure oil applies to low pressure outlet port valve C4 time valve low pressure port A1 this time valve low pressure port B5 is closed and valve high pressure B3 is opened the upper chamber of the piston A1 to rise the pressure in the lower chamber of the piston A1.

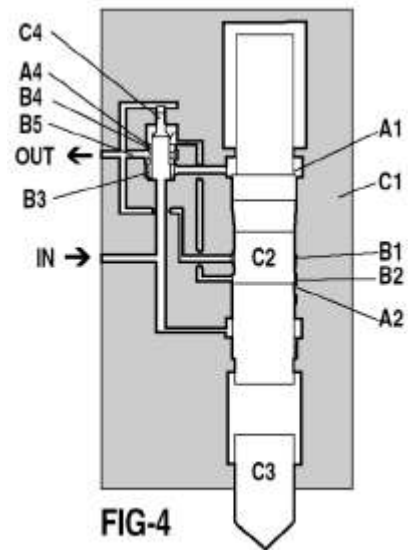

A1 : Area of the upper chamber of the piston
 A2 : Area of the lower chamber of the piston
 A3 : Area of valve high pressure chamber
 A4 : Area of valve change chamber
 B1 : Cylinder low pressure port
 B2 : Cylinder change port
 B3 : Valve high pressure port

B4 : Valve change port
 C1 : Power cell
 B5 : Valve low pressure port
 C2 : Piston
 C3 : Tool
 C4 : Valve

4. Construction and Main Parts (Outward Valve Type)

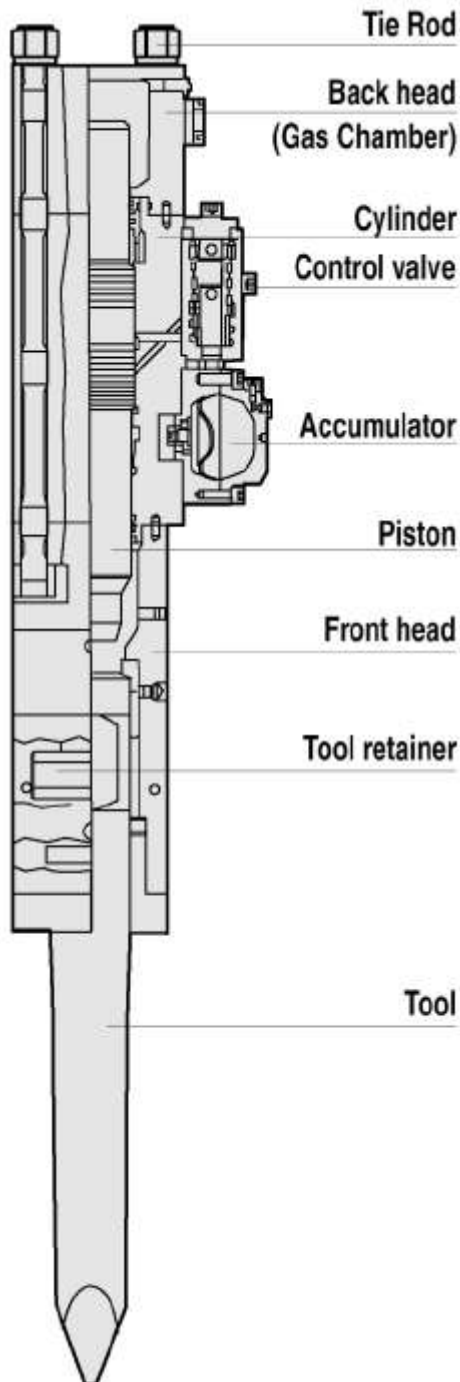

- **Tie Rod**
Front head, cylinder and back head of breaker body are tightly fixed with four tie rods.
- **Back Head**
Gas charging valve is built in and the inside is charged with N₂ gas.
- **Cylinder**
The cylinder is the heart of the breaker containing hydraulic circuit for piston reciprocation.
- **Control Valve**
Cylindrical control valve is built in the valve housing to control piston reciprocation.
- **Accumulator**
The accumulator compensates the pressure in the hydraulic circuit and prevents pulsation. It is not usually necessary to refill. Use N₂ gas only.
- **Front Head**
The front head supports the whole breaker components. Upper bushing prevents shock from the tool.
- **Tool**
The specially heat-treated tool is directly applied to break rocks. It has various forms of a wedge, moil point, blunt, cone and wedge chisel appropriate to the application. (optional)

1. SET UP

Chambers C3, C2 always maintain low pressure because they are connected to the output line. Chambers V3, V1, C1, and accumulator always maintain high pressure because they are connected to the input line.

Chamber V2 pressure is changed to low pressure or high pressure depending on piston position.

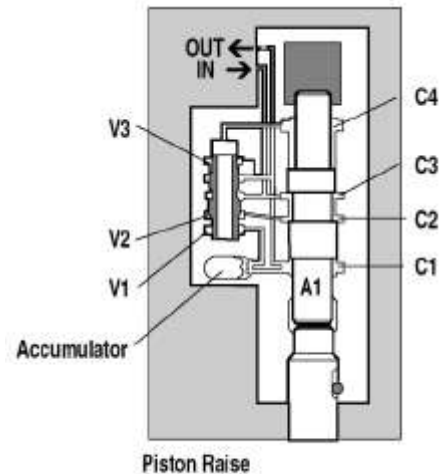

2. PISTON RAISE

Oil enters into "IN" port, and begins to accumulate force to raise piston; hydraulic force is applied on A1 of piston lower flange and piston begins to be raised.

When the piston begins to be raised, oil from C4 chamber returns to the output line through the control valve.

3. VALVE RAISE

When piston be raised to around upper limits, A1 of piston lower flange reaches chamber C2, and the back head nitrogen(N₂) gas is compressed.

At this time, oil from chamber C2 goes to chamber V2.

A3 area is larger than A4 area, but applied pressure of area A3 is the same as applied pressure of area A4.

Therefore, the valve begins to be raised, because of the area difference between A4 and A3.

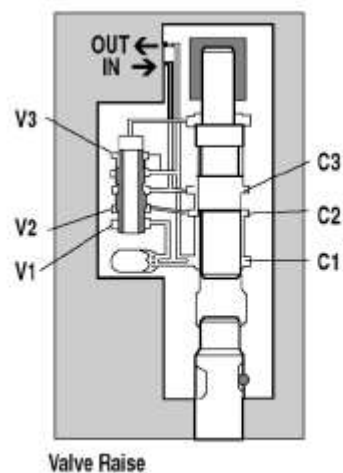

4. PISTON DESCENT

When the valve reaches the upper limits, chamber C4 becomes high pressure area because oil from the working pump goes to chamber C2 through the control valve holes. A2 area is larger than A1 area, but pressure applied to A4 area is the same as them pressure applied to A1.

Therefore, the piston begins to be descended, because of the area difference between A2 and A1.

At this time, piston descent speed is accelerated by compressed nitrogen (N2) gas pressure and piston weight.

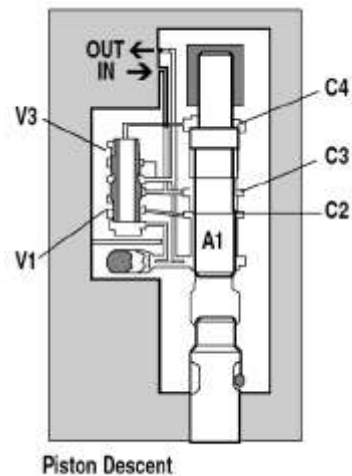

5. IMPACT

Chamber V2 is changed in low pressure as chamber C2 is connected with C3 during piston descent.

But V3 is always high pressure. Therefore, the valve begins to be descended.

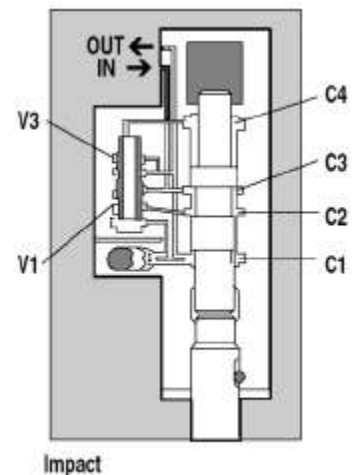

6. CONTINUOUS STRIKE

After the piston strikes the top of the tool, the status of all circuits is changed to "Piston Raising". The piston begins to be raised via status flowing into "IN" port and the cycle is repeated again.

5. Preparation for Installation and Operation

1. GENERAL VIEW OF BREAKER INSTALLED

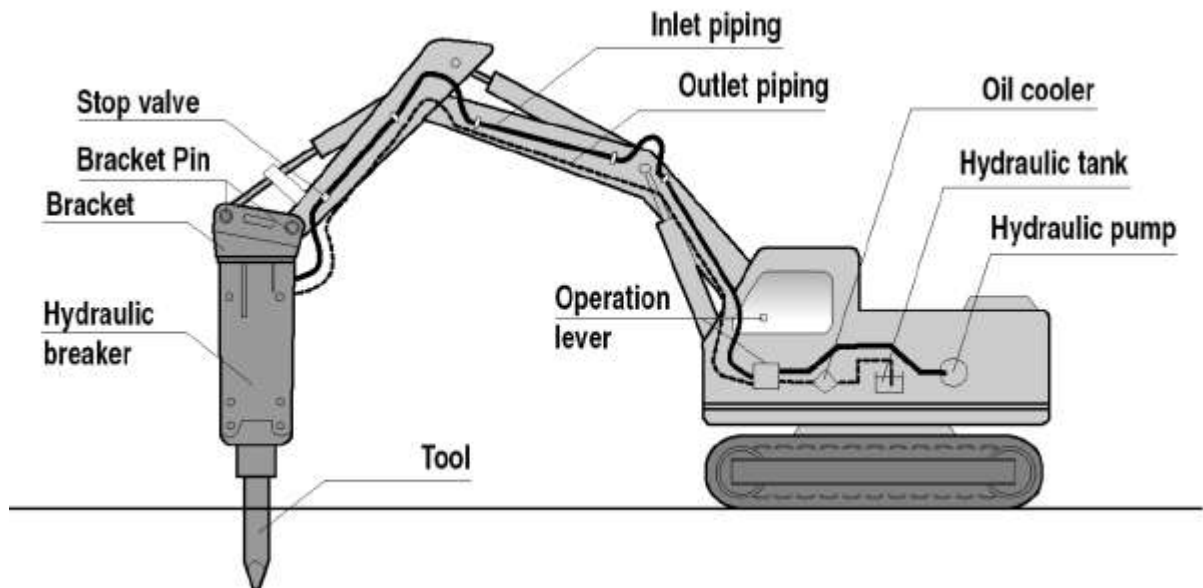

2. HYDRAULIC PIPE LINES FOR EXCLUSIVE USE

Operation of the hydraulic breaker requires installation of hydraulic pipe lines for exclusive use of the hydraulic breaker. As hydraulic pipe lines vary depending on base machines, our service engineer must first check hydraulic pressure, oil capacity, pressure loss and other conditions of the base machine before installing hydraulic pipe lines. Use only genuine parts in case of replacement because hydraulic pipe lines (hoses, pipes and fittings) are made of materials carefully selected in consideration of durability.



WARNING

THE HYDRAULIC SYSTEM TO THE BASE MACHINE MUST BE CHECKED BY AN AUTHORIZED TORPEDO SERVICE ENGINEER BEFORE FIRST USE AND AFTER ANY MODIFICATIONS



WARNING

MAKE SURE THAT THE BREAKER VALVE OF HYDRAULIC SYSTEM IS PROPERLY SET

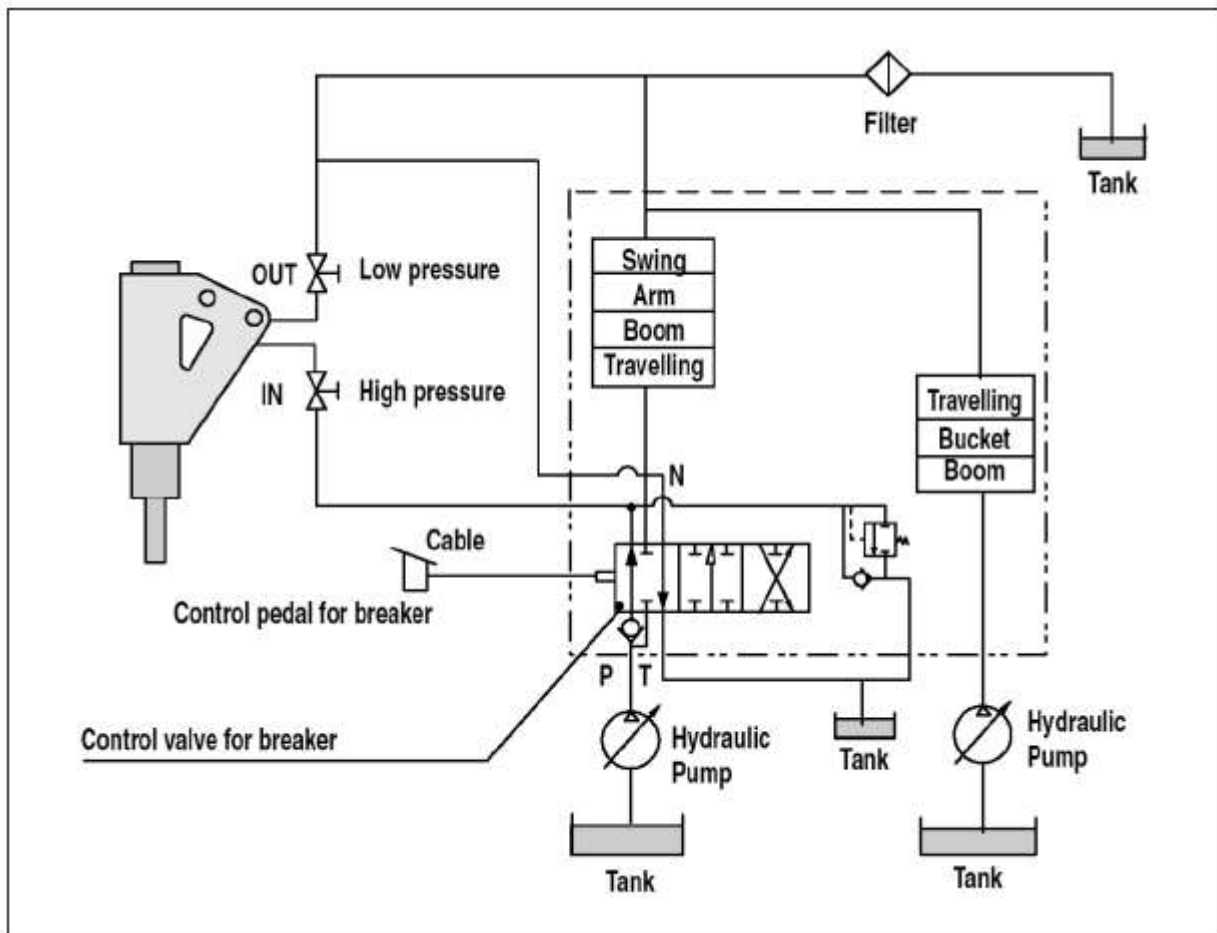

3. CHECKING – BEFORE INSTALLING INSTRUCTIONS



WARNING

1. CHECK THE “SPECIFICATIONS” SECTION OF THIS MANUAL TO DETERMINE CORRECT BACKHOE AND EXCAVATOR SIZES, HYDRAULIC PRESSURE, AND HYDRAULIC FLOW REQUIREMENTS.
2. IF HYDRAULIC PRESSURE, HYDRAULIC FLOW ARE EXCEEDED, THE BREAKER WARRANTY IS NOT APPLIED.
3. CHECK THE NITROGEN GAS – BACK HEAD AND ACCUMULATOR.
4. BE SURE THE FLUID IN THE HYDRAULIC SYSTEM IS CLEAN.
5. CHECK THE HYDRAULIC FILTER, REPLACE THE FILTER IF DIRTY OR DETERIORATE
6. HOSE AND PIPING MUST BE FLUSHING.
7. THE CONTAMINATED PART MUST BE CLEANED WITHOUT DELAY.
HYDRAULIC OIL OR LIGHT OIL IS HIGHLY RECOMMENDED.

IMPORTANT

THE CIRCUIT RELIEF SETTING PRESSURE IS NOT FIXED. HOWEVER,
IT WILL BE ADJUSTED BY PUMP CAPACITY

4. INSPECTION AND CHARGING OF N₂ GAS IN BACK HEAD



WARNING

1. CHARGING GAS PRESSURE CHANGES ACCORDING TO THE TOOL CONDITION.
LAY DOWN THE BREAKER AND LET THE TOOL EXTEND FULLY TO CHARGE GAS.
2. STAY CLEAR OF THE TOOL WHILE CHARGING THE BREAKER WITH GAS. THE TOOL MAY BE IMPACTED BY THE PISTON AND FORCED OUT ABRUPTLY.
3. TAKE CARE WHEN THE TIE RODS ARE CHANGED OR THE BREAKER BODY IS DISASSEMBLED.
4. USE SPECIAL CARE TO HANDLE AND STORE THE N₂ GAS CYLINDER AS IT IS A HIGH-PRESSURIZED CONTAINER.
5. USE NITROGEN GAS ONLY
6. SEE "CONVERSION TABLE FOR CHARGING N₂ GAS PRESSURE TO BACK HEAD"

● **Charging of N₂gas into back head**

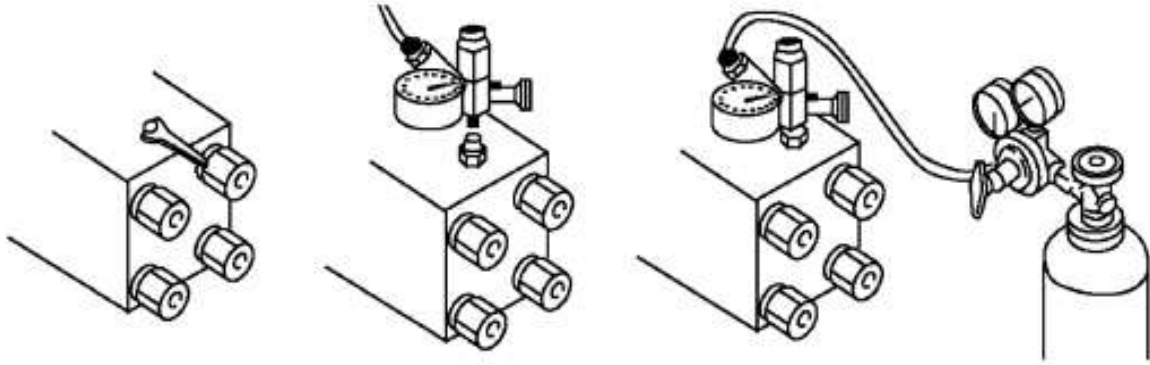

(1) Remove gas valve plug

(2) Insert 3-way valve with pressure gauge assembled (Note. 1)

(3) If gas is insufficient, adjust to specified valve as shown in the previous page (Note. 2)

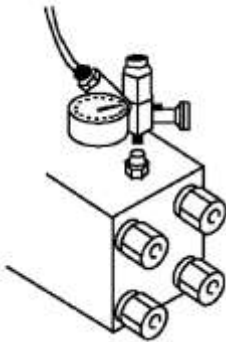

(4) Adjust the pressure slowly, decreasing it by using the pressure gauge if gas is sufficient

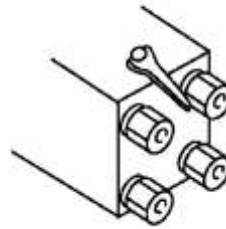

(5) Tighten gas valve plug (Do not cut O-ring)

 **Note**

- Insert 3-way valve after its handle is fully turned counterclockwise.
- Turn the 3-way valve handle clockwise slowly. Stop turning it when the needle of the gauge starts to move. If it is turned clockwise too tightly, the valve may easily be damaged. Pay special attention to ensure that the nitrogen gas is not charged excessively.

● **Conversion table for charging nitrogen gas pressure to back head**
(Depends on the temperature of the back head surface)

DSBREAK (Inward Valve Type)

Back head gas Pressure	Ambient Temperature(/)				
	0 / 32	10 / 50	20 / 68	30 / 88	40 / 104
kg/cm ²	15.5	15.9	16.3	16.8	17.3
psi	220	226	231	238	246

5. INSPECTION AND CHARGING OF N GAS IN ACCUMULATOR



WARNING

- USE SPECIAL CARE TO HANDLE AND STORE THE N₂ GAS CYLINDER AS IT IS A HIGH-PRESSURIZED CONTAINER.
- USE NITROGEN GAS ONLY.
- SEE “CONVERSION TABLE FOR CHARGING N₂ GAS PRESSURE TO ACCUMULATOR”
- STANDARD ACCUMULATOR GAS PRESSURE 55kg/cm²/ 780psi, AT 20 /68 AMBIENT TEMPERATURE, DO NOT OVER PRESSURIZE ACCUMULATOR.

Cautions for charging N₂gas to the accumulator

- Be sure to use the 3-way valve assembly for charging the N₂gas.
If charging gas leaks directly from the cylinder, the diaphragm may be broken off.
- If charging for handing N₂gas to only the accumulator, make sure that the accumulator body and cover are tightened fully.
 - Make sure the cap and valve of the 3-way valve assembly are fully tightened.
 - Remove the cap from the accumulator and tighten the charging valve fully.
 - Check if O-rings are installed to the bushing. Remove the plug and screw in the bushing.
 - Install the bushing to the 3-way valve assembly.
 - Loosen the charging valve gradually. The charging pressure is indicated on the pressure gauge.
 - Close the valve clockwise when the gas pressure is normal. When the gas pressure is higher, repeat loosening and tightening the valve assembly. The pressure is lowered gradually.
 - Loosen the valve of the 3-way valve assembly to discharge the N₂gas in the 3-way valve assembly.
 - Remove the 3-way valve assembly and tighten the plug and cap.
- Charging of N₂ gas into accumulator
 - Connect the charging hose to N₂gas cylinder after screwing the valve adapter on to adapter, nut and installing to the N₂gas cylinder.
 - Connect the 3-way valve assembly to the charging hose after unscrewing the cap on the 3-way valve assembly.
 - Remove the cap from the accumulator and tighten the charging valve fully.
 - Check if Orings are installed to the bushing. Remove the plug and screw the bushing.
 - Loosen the accumulator charging valve after checking if bushing is installed to the 3-way valve assembly.
 - Turn the handle of the N₂gas cylinder counter clockwise slowly to charge the gas.
 - Charge the gas in accordance with the conversion table for charging N₂gas pressure to accumulator.
 - Turn the handle of the N₂gas cylinder clockwise to close the cock.
 - Close the accumulator charging valve.
 - Loosen the valve of the 3-way valve assembly to discharge the N₂gas remaining in the charging hose.
 - Remove the charging hose, 3-way valve assembly and bushing and tighten the plug and cap.

- Conversion table for charging nitrogen gas pressure to accumulator.

DSBREAK Series

Accumulator gas Pressure	Ambient Temperature(°C/°F)				
	0 / 32	10 / 32	20 / 68	30 / 86	40 / 104
kg/cm ²	50	52	55	58	61
psi	711	739	780	824	867

● **N2 gas charging pressure to Accumulator**

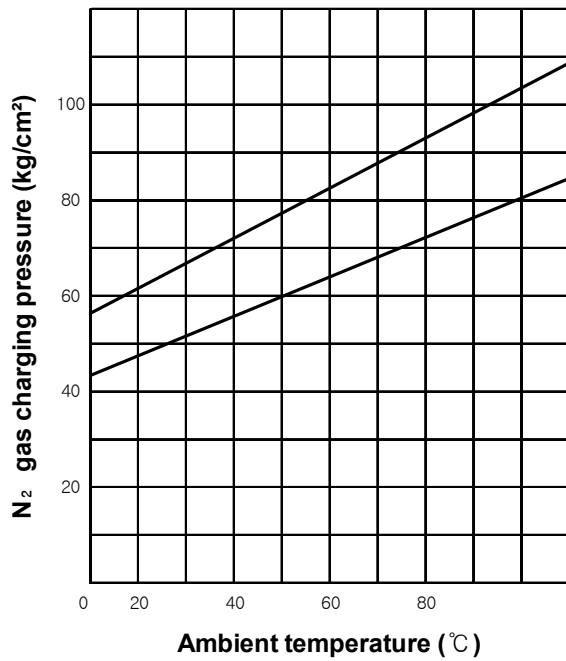

- Conversion table for charging N2 gas pressure to accumulator

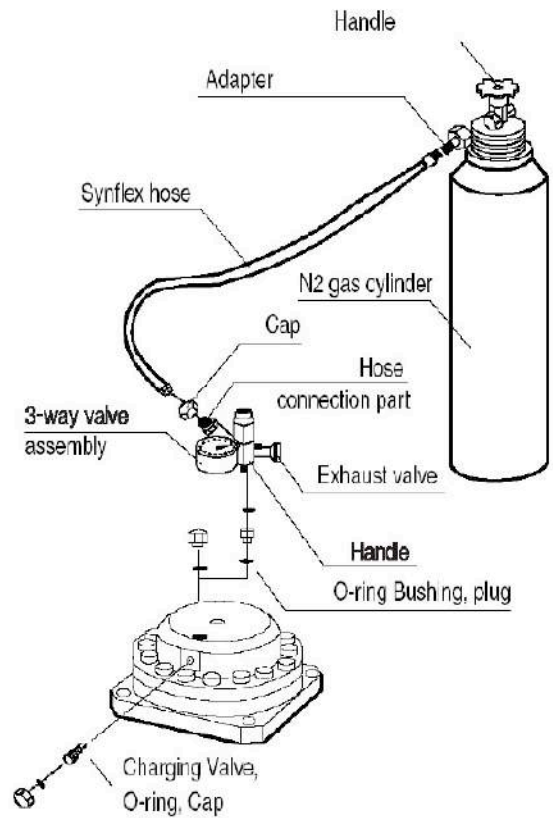

6. HYDRAULIC OIL

● **Selection of oil**

- Selection of hydraulic oil determines the efficiency of the hydraulic breaker performance. Please consult with our service station under following conditions.
- When used in special regions where climate is severe (e.g. extremely cold or hot weather)
- When recommended Dsbreak hydraulic oil are not available.
- When hydraulic oil supplied

● **Hydraulic Oils and Greases**

Recommended for Hydraulic Breaker by Dsbreak

LUBE & SPEC LUBRICANTS MANUFACTURE	Hydraulic Oil			Grease
	Summer	Winter	All Season	(MOS ₂)
	ISO VG 46	ISO VG 32	ISO VG 46	NLGI No ₂
MOBIL	MOBIL DTE25	MOBIL DTE 24	MOBIL DTE 15M	MOBIL GREASE SPECIAL
	MOBIL SHC 525			MOBILTH SHC 220
	MOBIL EAL SYNDRAULIC 46			
LG-CALTEX	RANDO HD 46	RANDO HD 32	RANDO HD CZ	MOLYTEX EP2
BP	ENERGOL HP 46	ENERGOL HP 32	ENERGOL HP 46	-
SHELL	TELLUS 46	TELLUS 32	TELLUS T 46	RETINAX HDX-2

- Synthetic lubricant
- Environmentally friendly synthetic lubricant
- **Oil Contamination**

- Contaminated oil results in malfunctions of the breaker as well as the base machine and cause damage to parts. Pay special attention to oil contamination.
Contaminated oil should be changed without any delay. When changing oil, thoroughly wash oil tank, cylinder and pipes. Cleaning or replacing oil filter also requires check for oil contamination.
- Replacement of filter : after first 50 hours and every 100 hours thereafter
- Replacement of hydraulic oil : every 500 hours



WARNING

- **HYDRAULIC OIL TEMPERATURE AND VISCOSITY**

Do not operate the hydraulic breaker at oil temperatures from 20°C / 68°F to 80°C / 176°F. Operation at higher temperatures can damage the internal components of the breaker and excavator, there will result in reduced breaker performance.

- **Criteria of oil contamination and malfunction**
(General Analysis)

Analysis Item	Criteria	Causes and Effects when exceeds the criteria
Adhesiveness	Within $\pm 10\%$ 40°C cSt	Adhesiveness rarely decreases solely because of hydraulic oil. Entry of different kind of oil may reduce the adhesiveness which contributes to rising oil temperature, wear and stretch of bearings and gears and malfunction of hydraulic oil.
Oxidizing Level	Less than 0.3 (mg KOH/g)	Use of a lubricating oil in a long period of time of under high temp of a lubricating (higher than 60°C) will oxidize it. Oxidizing level rises as oxidization proceeds. Sludge will be produced during the process. Leading to unsatisfactory operation of the breaker, erosion of metals or obsolescence of seal materials.
Moisture	Less than 0.1 (%)	Moisture causes rust, wear and scratch. Moisture of 1.3% gathers a considerable amount of rust. And considerable a mount of rust moisture of 0.5% or more will cause damage to the machine.

- **Criteria of malfunction by hydraulic oil color**
(Simple discrimination by ASTM color)

Hydraulic oil turns black as the breaker fails to display best performance.

The old oil is assumed to be contaminated when there is a visual difference between the old and new oil color and functions begin to deteriorate when hydraulic oil turns darker than the new oil color (ASTM number) by more than two.

6. Operation (Breaking)

1. PROPER POSITION OF THE TOOL

Proper position must be applied for an effective use of breaking force. When position is incorrect, blowing energy of the piston is too weak to break rocks.

Instead, blowing force applies shocks to the breaker body, breaker, arm, and boom of the base machine, thereby resulting in damage to those parts.

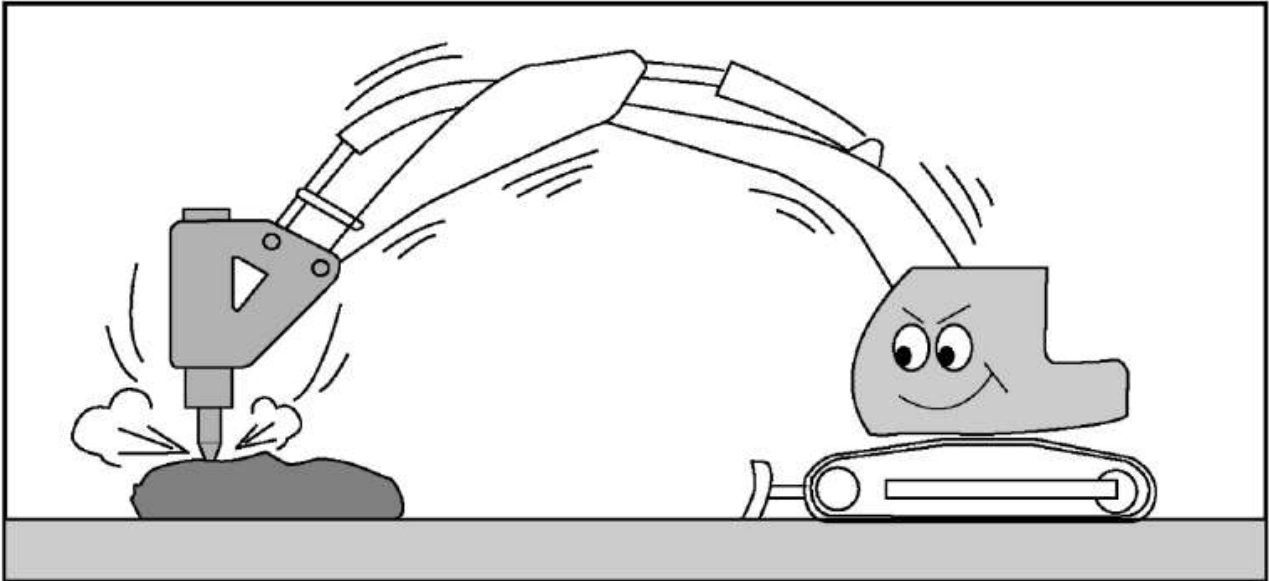

On the contrary, when position is excessive enough to break rocks with front of the base machine raised, the machine may suddenly tilt forward the moment rocks are broken then the breaker body or the end of bracket may violently hit against rocks and result in damage.

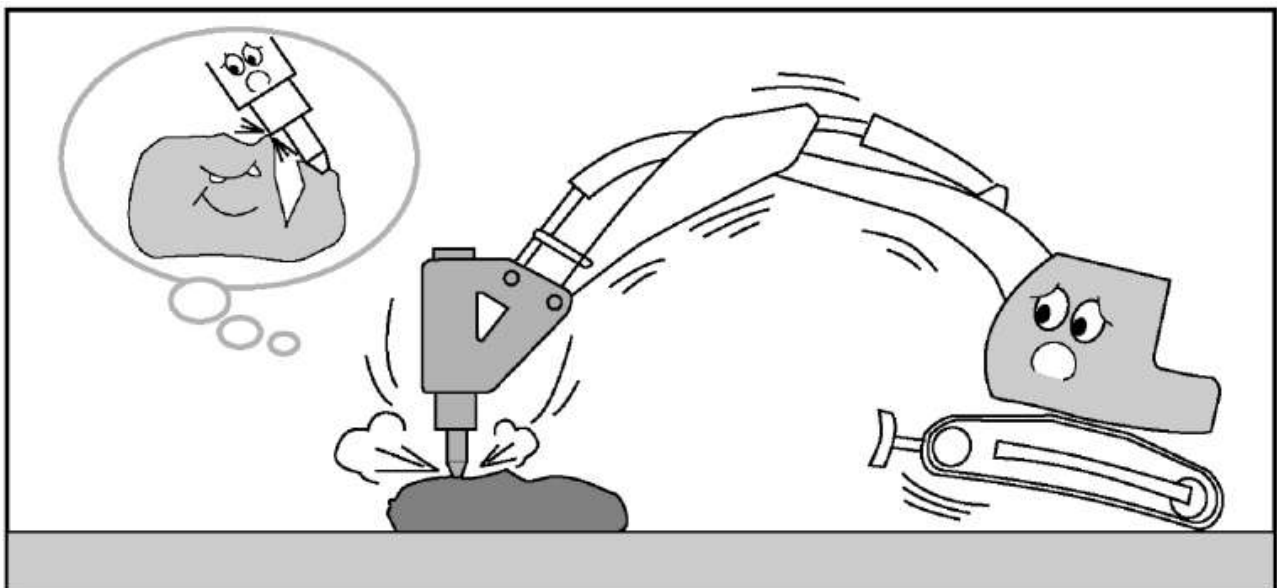

It is undesirable to carry out hammering under the below condition, because vibrations during hammering may be transmitted to tracks of the base machine. During hammering, however, proper position must be always applied to the breaker. Special care must be taken not to hammer under abnormal condition.

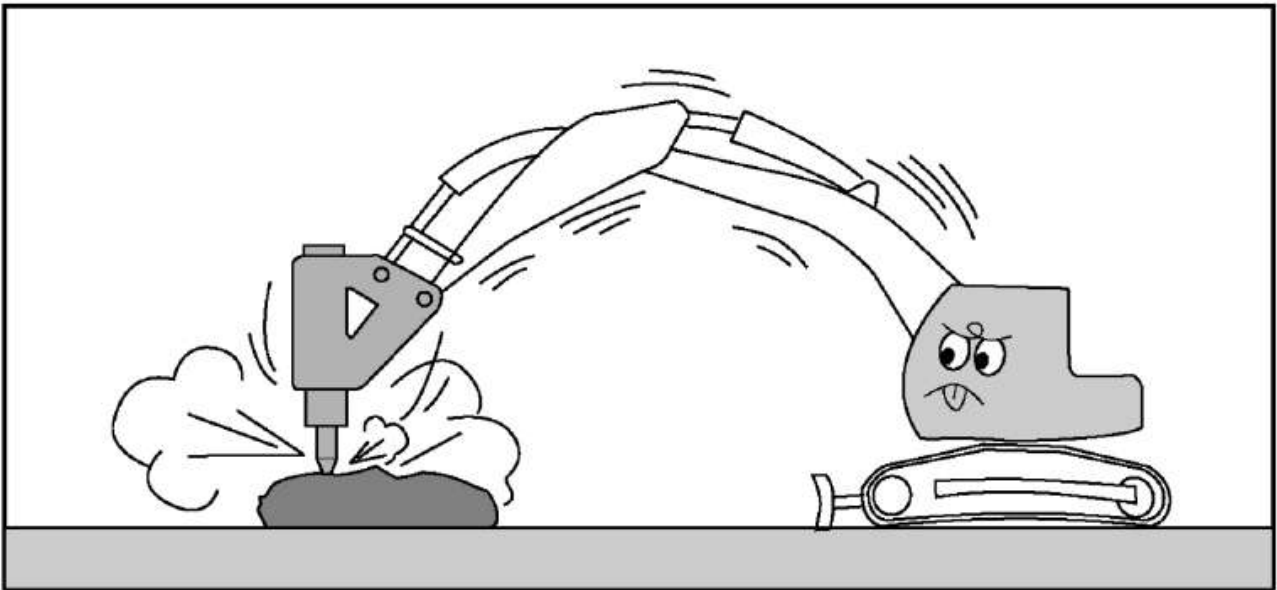

2. ALIGNMENT OF THE TOOL

Apply same direction of boom force in line with the tool and place the tool in the rock with hammering surface as vertical as possible. If hammering surface is oblique, the tool may slip during hammering. This causes the tool to seize and to be broken and piston to be damaged. When breaking, fully stabilize the tool first and then select the point of a rock on which hammering can be performed in a stable condition.

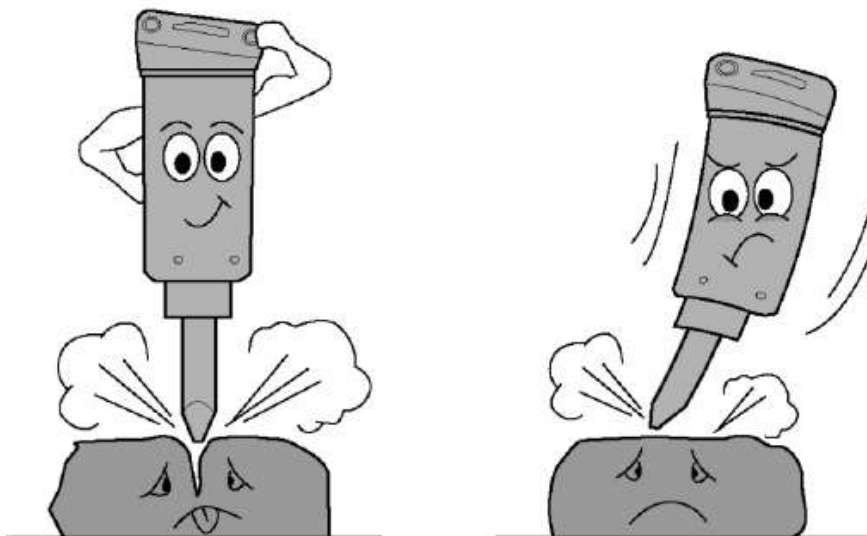

3. OPERATION PRECAUTIONS

IMPORTANT

- APPLY DOWN FORCE TO THE BOOM DIPPER UNTIL THE FRONT OF THE BACKHOE AND CARRIER IS ARISED OFF THE GROUND.
 - THE BREAKER IS MORE EFFICIENT WHEN ADEQUATE DOWN FORCE IS APPLIED.

IMPORTANT

- RELOCATE THE BREAKER OFTEN
 - THE BREAKER TOOL SHOULD BE MOVED TO A NEW LOCATION OF THE WORK EACH TIME THE TOOL PENETRATES BUT DOSE NOT CRACK THE MATERIAL

IMPORTANT

- DO NOT BREAK CONTINUOUSLY IN ONE PLACE
 - CONTINUOUS PENETRATION IN THE SAME AREA FOR LENGTHILY PERIODS WILL CREATE EXCESSIVE TEMPERATURES AT THE END OF TOOL RESULTING IN LOSS OF TEMPER [HARDNESS] OF THE BIT AND CAUSING MUSHROOMING OF THE TIP OF THE BIT, AND MAY LEAD TO FAILURE OF THE BIT.

IMPORTANT

- DO NOT PRY WITH THE BIT AND BREAKER.

IMPORTANT

- THE CONTAMINAED PART MUST BE CLEANED WITH NO DELAY.
HYDRAULIC OIL OR LIGHT OIL IS HIGHLY RECOMMENDED.

Stop operation as soon as hose vibrate excessively.

Excessive vibration of high and low-pressure hoses of breaker calls for an instant disassembly and repair. Contact the nearest service station appointed by Dsbreak . For caution's sake, check oil leakage at back head.

- The operator is required to pay attention to following points during operation.

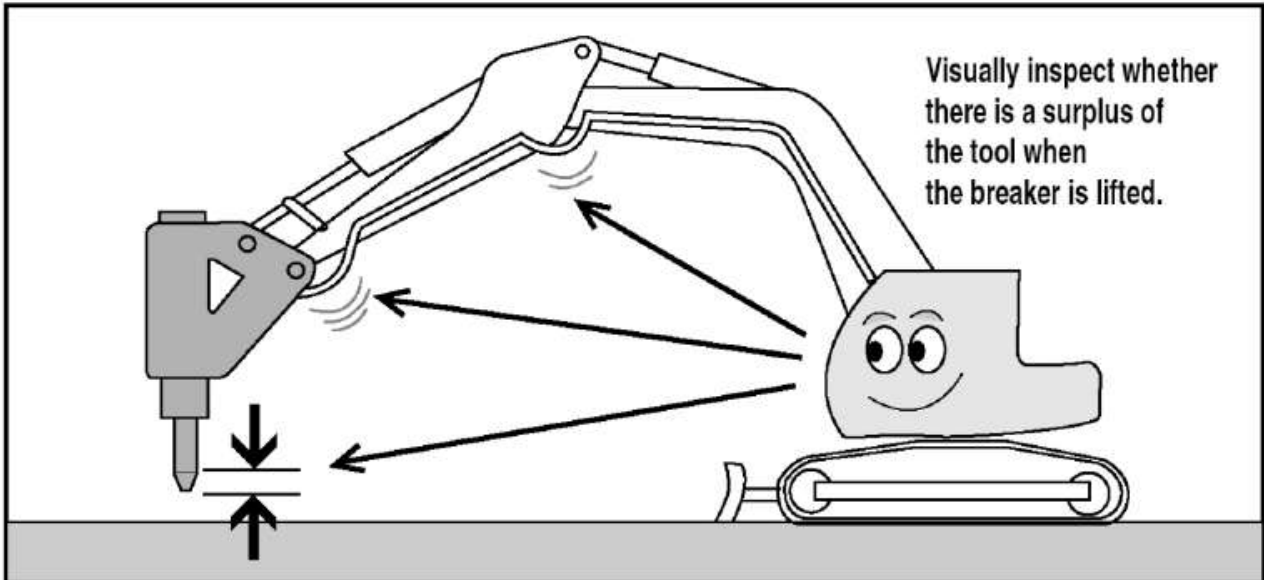

● **Avoid all blank hammering.**

As soon as rocks are broken, stop hammering. Continuous blank hammering will not only damage front head and loosen and break bolts, but also adversely affect base machine. Blank hammering occurs when proper position of the tool is not applied to the breaker or the tool is used as a lever. (Hammering sound changes during blank hammering)

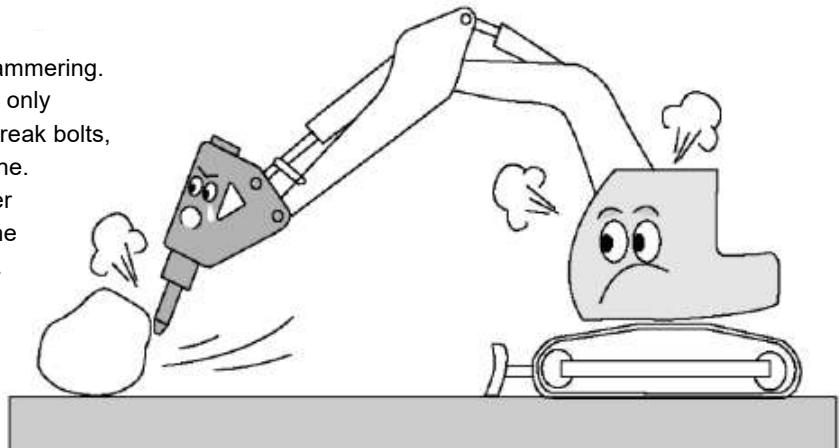

● **Do not move rocks.**

Avoid moving rocks with side of the bracket, because it is the major factor to break bolts installed on the bracket, tool and damage boom and arm.

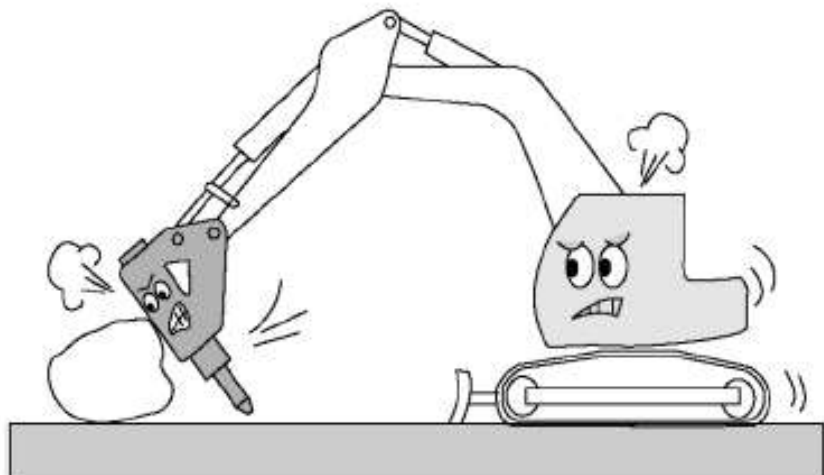

Do not use tool as a lever.

When breaking rocks by using tool as a lever, bolts and tool may be broken too.

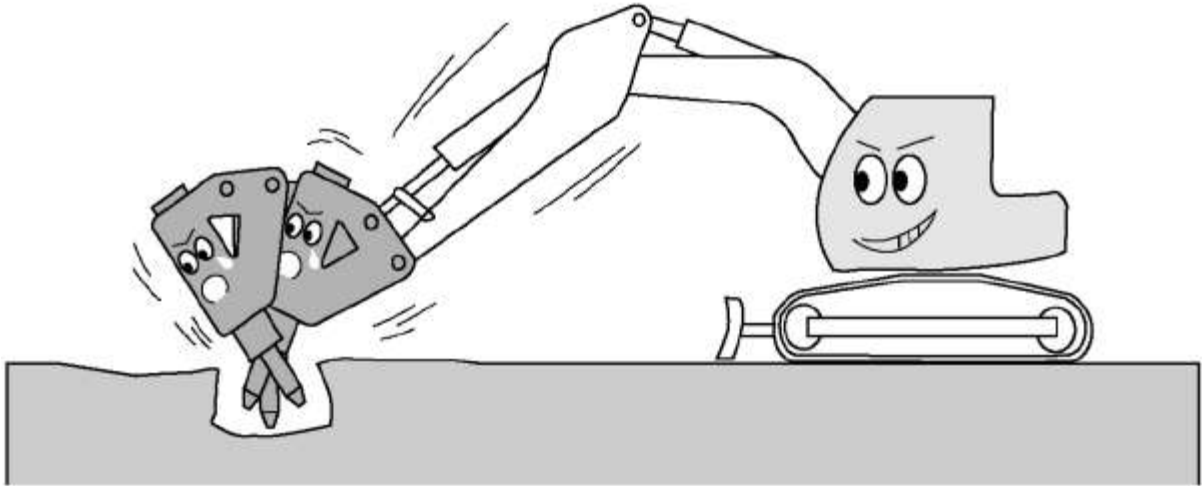

● **Do not continue to hammer for more than one minute.**

When rocks are not broken after more than one minute's hammering at the same point, change the place to be hammed. Extended hammering at the same place causes the tool to wear out excessively.

● **On a hard and large rock, start breaking at start breaking from the edge.**

Even a hard and big rock can be easily broken when hammering begins at a crack or an edge.

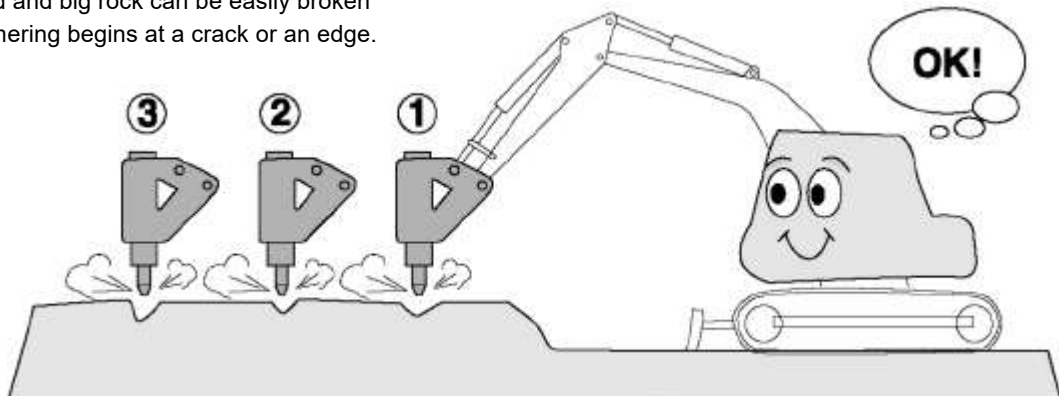

● **Operate breaker at proper engine speed.**

Break rocks at the specified engine speed. Raising engine speed more than necessary does not strengthen hammering force but increase oil temperature to the detriment of pistons and valves.

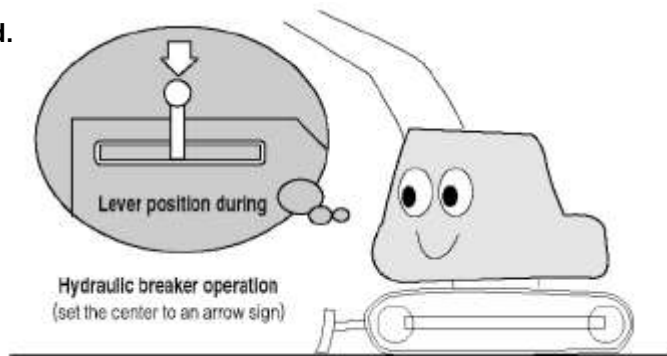

- **Do not operate the breaker in water and mud.**

When rocks are not broken after more than one minute's, Do not operate breaker when all components except tool are immersed in water and mud. Piston and similar components may gather rust and become a damaged breaker at an early stage.

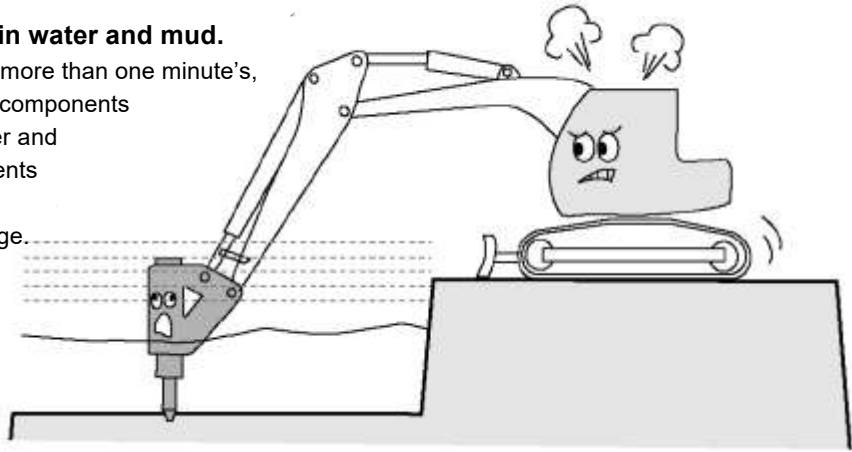

- **Do not allow the breaker to fall to break a rock.**

Falling down the breaker will apply excessive force to the breaker or the base machine, causing damage to many parts of the breaker and the base machine.

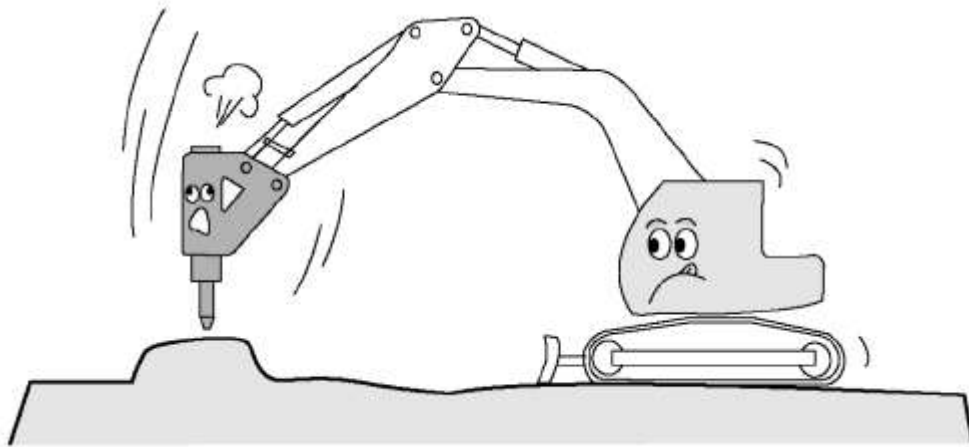

- **Do not hammer with base machine cylinders moved to stroke end.**

Hammering with each base machine cylinder moved to stroke end (a condition that the cylinder is fully extended or retracted) will do considerable damage to the cylinder and each part of the base machine.

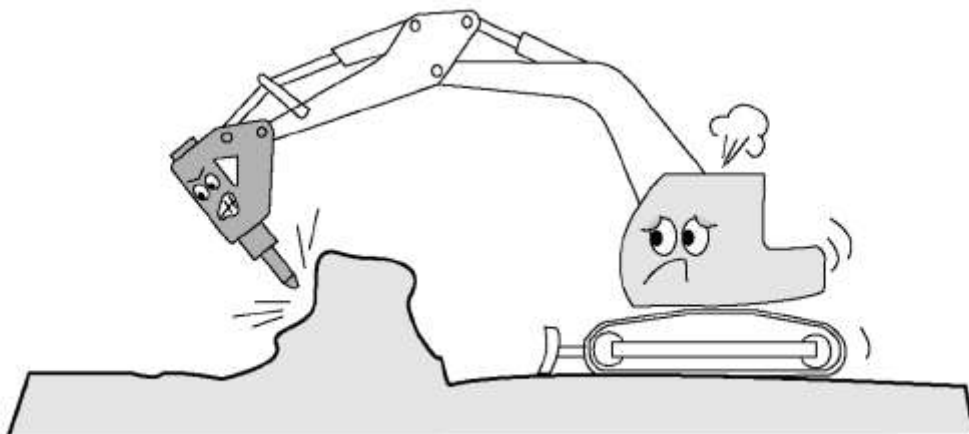

- **Do not lift things with the breaker.**

Lifting materials by hanging wire in the bracket or tool not only causes damage to the breaker but also is very dangerous when operating.

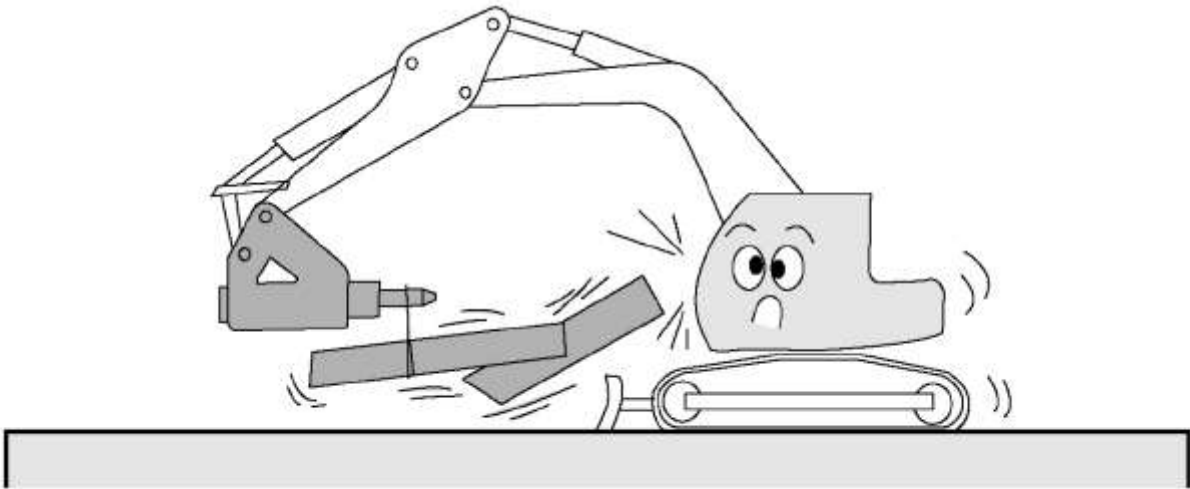

- **Warm up base machine engine prior to operation.**

Especially in winter, the base machine engine should be warmed up for five to ten minutes 30°C~40°C (86°F~105°F) before breaker operation. Follow the instruction book for base machine to warm up the engine.

- **Do not touch tool for breaker working**

While the breaker is working, high temperature of the tool will be generated.

- **When operating the breaker, you must use ear and body protection**

You must use ear and breathing protection when the breaker is operating.

- **Accumulator type danger**

Attention to pressurized container! Do not open without reading the manual or consulting with the authorized service personal!

- **Greasing**

With breaker mounted on carrier, Apply down pressure on tool, and fill cavity with recommended grease through the grease nipple.

- **Always wear eye protection when.**

Stop pin is being removed it in and out with a punch and hammer.

7. Installation and Removal of the Hydraulic Breaker

When the bucket and breaker operation are performed alternately, the bucket and breaker can be easily exchanged by the hydraulic hoses and two pins. There is, however, a risk of the hydraulic circuit contamination. Accordingly, install and remove as follows.

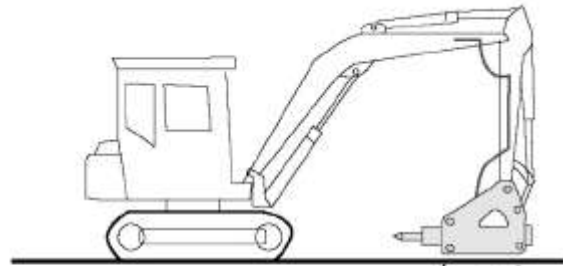

Wood block

Position of the base machine for installation and removal of the hydraulic breaker

- Move the base machine to stable ground free from mud, dust, and dirt. Stop the engine, turn off the main switch and deflate air from oil tank if it is pressurized.

- Turn 90° the stop valve installed to the end of arm to prevent hydraulic form flowing out.

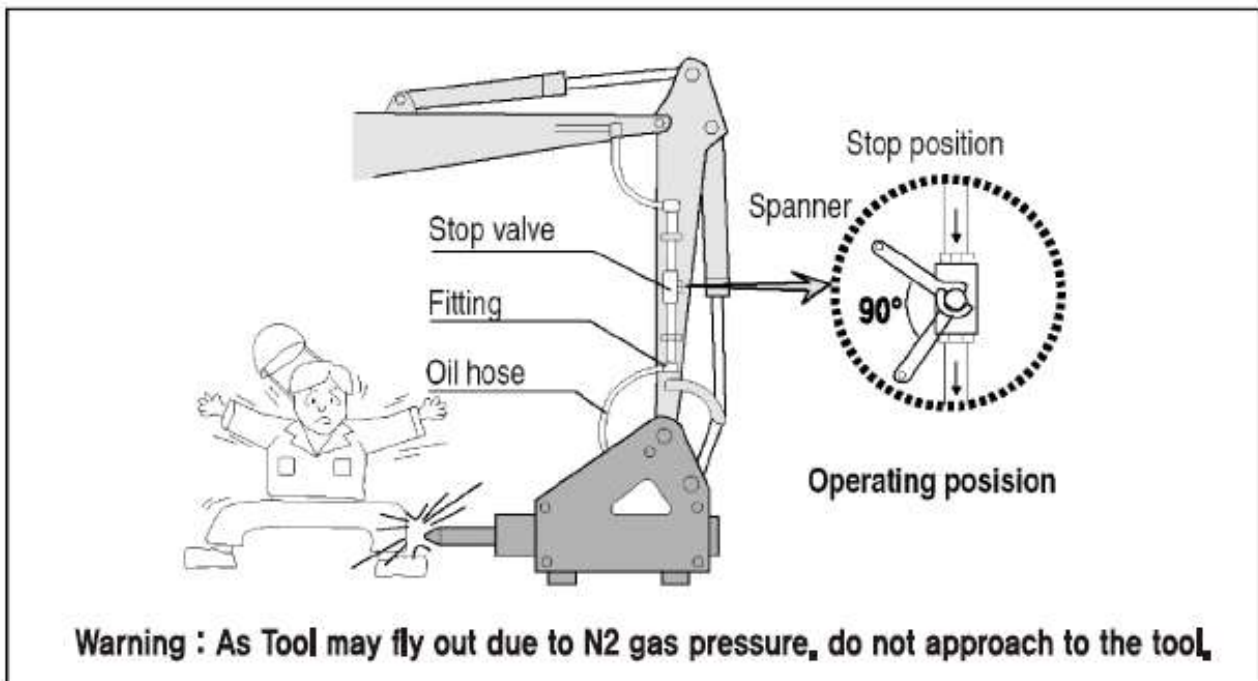

- Loosen hose plug on the breaker arm. Collect small amount of oil flowing out at this time and put into a container.

- Be careful to prevent mud or dust from entering oil hoses and pipe lines.

Plug oil hoses with hose plug and pipe lines with union caps. Bind high and low-pressure hoses with a wire to prevent them from getting mud.

- **To remove the breaker, pull out pins in the bucket link and arm.**

When leaving the breaker outdoor, set the breaker on wood blocks and cover with sheets.

- **When leaving the breaker removed for a long period of time.**

- Clean exterior of the breaker.
- Remove tool from the front head and spray with rust preventive oil.
Bleed N2-gas from the back head before pushing piston into cylinder.
- Apply grease to each part of the breaker and then install tool again.

- **To install the hydraulic breaker, reverse the fore mentioned removal procedures.**

The bucket operation easily contaminates the end part of hoses and pipe lines. The contaminated part must be cleaned with no delay. Hydraulic oil is highly recommendable.



CAUTION

- Never insert your hand or fingers into the pin hole



WARNING

- While aligning the arm hole, or moving the bucket, make sure that there are no person in the vicinity of arm or bucket of base machine.
- It is dangerous to move the base machine suddenly during installation.
- Wear the safety shoes to protect feet.

NOTICE

- Be careful so that dust may not enter the hydraulic breaker and base machine.
- Install or remove the hydraulic breaker on horizontal ground without mud or dust.

- 1) Set the hydraulic breaker on horizontal ground.
- 2) Remove the bucket from the base machine after disassembling the two pins.

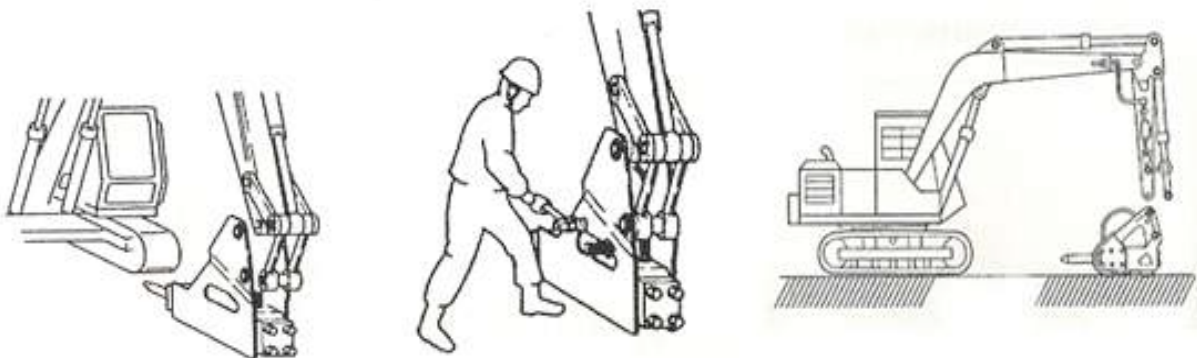

NOTICE

- If the bucket cylinder is retracted, the installation will be easier.

- 3) Move the base machine in the vicinity of hydraulic breaker, and align the pin hole of arm with the pin hole of hydraulic breaker, and then, insert the pins.
- 4) After the arm pin is inserted, lift the boom, reset the hydraulic breaker on the wood blocks like as Extend the bucket cylinder, fit it to the bucket link's hole and insert the pins.
- 5) Install the stop rings, align the bolt holes and insert the bolts. Mutually lock double nut.

NOTICE

- If the stop rings are secured with one nut only, the service life of the bolt may be shortened or the bolt may be loosened our very quickly.

- 6) Stop the engine of the base machine, tun off the main switch and discharge the air pressure in the hydraulic oil tank.
- 7) Remove the union caps from the hydraulic breaker pipe of the arm end, and connect the hoses after disassembling the hose plug.

NOTICE

- Do not allow the oil to drop onto the ground.
- Store the removed union cap and hose plug in the tool box.
- When installing or removing the oil hose and union cap, clean them fully to prevent the dust and mud from entering the hydraulic breaker or the base machine.

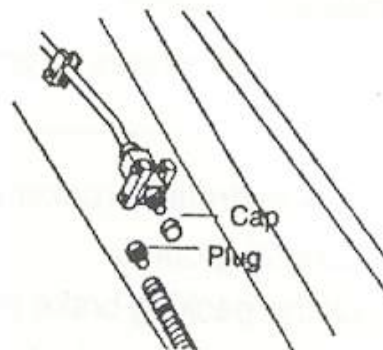
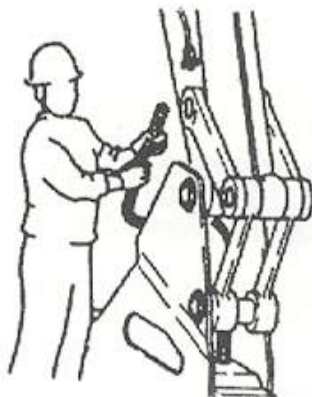



CAUTION

- Personal Injury can result from dropping pins during removal.



WARNING

- Wear safety shoes to protect feet.

- 1) Set the hydraulic breaker on clean and horizontal ground.
Lock the parking brake of base machine.
- 2) Stop the engine.
- 3) Turn stop valve to "OFF" position.
- 4) Disconnect hoses from stop valves. Ensure no leakage occurs from hoses and stop valves.
- 5) Apply union cap and plug to hose ends fittings to prevent.
- 6) Remove pins fixing fasteners.
- 7) Remove pins.
- 8) When pins have been withdrawn, move operating joystick slightly, to take weight off remaining link pin.
- 9) Lift arm away from hydraulic breaker so that hydraulic breaker can be carried away, or another attachment mounted on base machine.

NOTICE

- Cover the hydraulic breaker already removed with sheet, and then store it in doors.



8. Repair and Inspection

1. INSPECTION POINTS



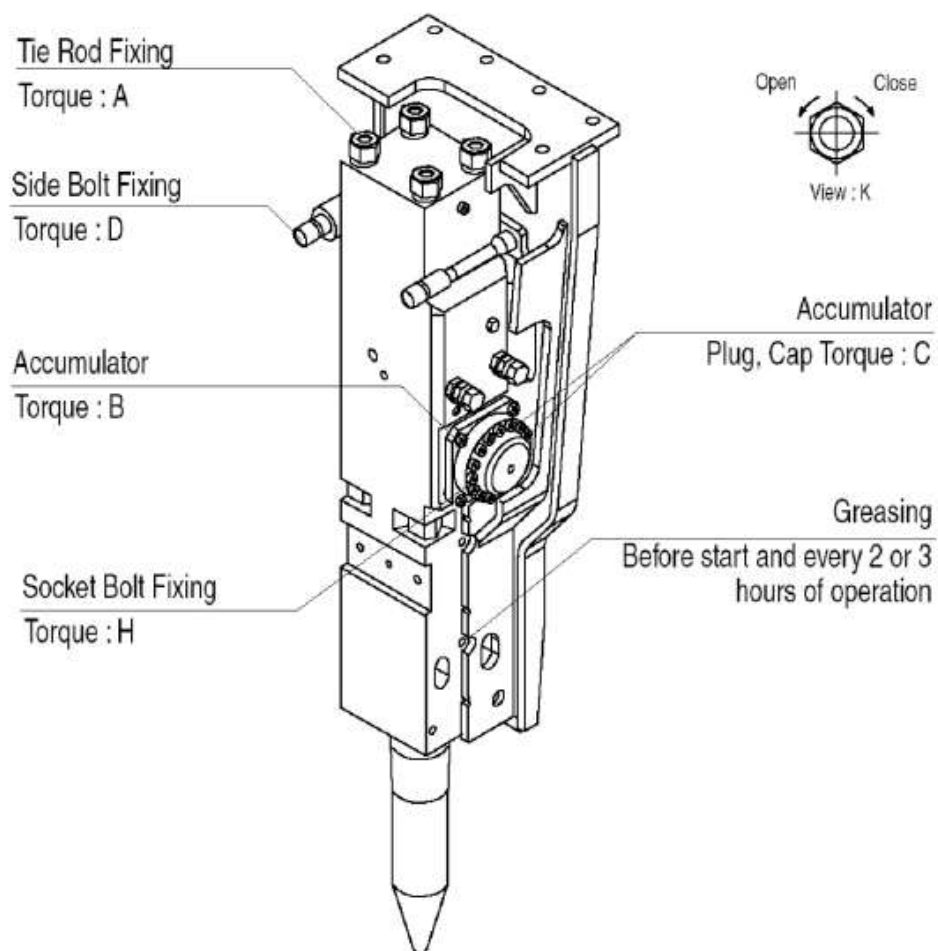

- DSBREAK

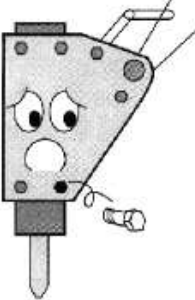
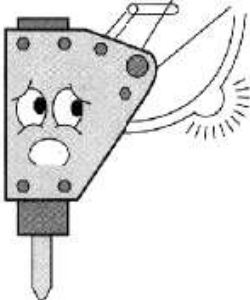

2. DAILY BREAKER INSPECTION

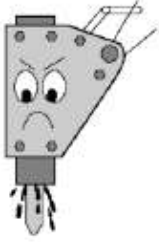
Before starting operation, be sure to inspect the breaker referring to the following table.

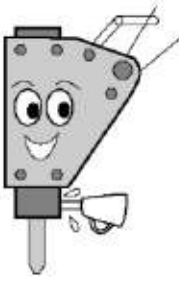
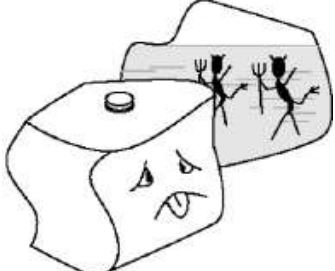
Inspection Item	Inspection Point	Remedy
<p>Looseness, missing and damage to bolts and nuts</p> 	<ul style="list-style-type: none"> ● Tie rod ● Bracket mounting bolts 	<ul style="list-style-type: none"> ● Check looseness ● Retighten securely
<p>Looseness, of hose fittings, visible damage to hoses and oil leakage</p> 	<ul style="list-style-type: none"> ● Hydraulic pipes for breaker - oil hoses 	<ul style="list-style-type: none"> ● Retighten securely. ● Replace seriously damaged parts.

Inspection Item	Inspection Point	Remedy
<p>Abnormal oil leakage</p> 	<ul style="list-style-type: none"> ● Connections of back head and cylinder ● Clearance between front head & tool (*But small leakage is normal from front-head) 	<ul style="list-style-type: none"> ● Consult with BEIYI BR EAK service station for further inspection.
<p>Abnormal wear and cracks on tool</p> 	<ul style="list-style-type: none"> ● Tool 	<ul style="list-style-type: none"> ● Deformed, burred and worn out tool should be repaired. ● Excessively worn tool needs to be replaced.
<p>Greasing</p> 	<ul style="list-style-type: none"> ● Grease at start and every 2 or 3 hours using head grease pump. ● Pumping;5~10 times (Greasing position and method shown at left.) ● When greasing, press the tool against on the ground. (See right fig) 	<ul style="list-style-type: none"> ● Grease front head.
<p>Level and contamination of hydraulic oil</p> 	<ul style="list-style-type: none"> ● Conditions of hydraulic oil 	<ul style="list-style-type: none"> ● Contamination of hydraulic oil carries with operating conditions, The oil color tells the level of contamination. ● Criteria for judging contamination is specifically Set by BEIYI BREAK ● When contamination is excessive, drain and flush the hydraulic oil tank and fill it with new oil.
<p>Missing rubber plugs and snap rings</p> 	<ul style="list-style-type: none"> ● Rubber plugs. ● Snap rings 	<ul style="list-style-type: none"> ● A seriously damaged part must be replaced.
<p>(Silence type breaker) Clearance of wear plate, guide plate, cushion etc...</p>	<p>Check every 3 month, if the wear-plate, guide-plate, cushions are good or not</p>	<p>If it is worn too much or damaged, replace the parts.</p>

3. REGULAR BREAKER INSPECTION AND MAINTENANCE

Regular inspection is essential for keeping hydraulic breaker operating in the best condition consult with the Comet service station for regular inspection and maintenance. Customers are recommended to contact the service station for inspection within six months after delivery.

4. REPLACEMENT OF TOOL

Tool is deformed or burrs produced in a long-term use. When a tool tip is worn out, tool is liable to slip. Then, sharpen the tool tip. Grinding the tool tip many times to sharpen the edge, however, it will make a heat-treated hardened surface layer disappear and it will wear out the tool rapidly. In this case, replace with a new tool. If a gap between tool and front cover ring becomes large, piston fails to fit in tool resulting in damage. When the gap is found in over 9mm, replace thrust ring together with the tool.

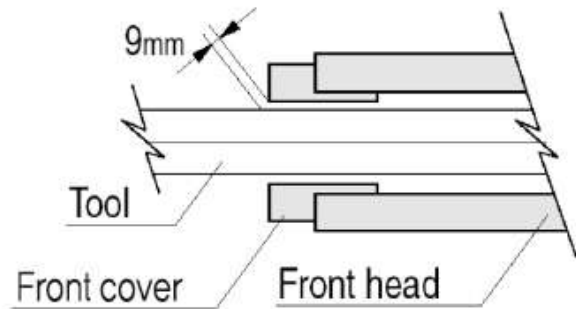

● Replacement Order

- Remove steel plug (or snap-ring) and tool pin in order with a 330mm-long steel bar. When reassembling, align groove in tool to tool pin hole and insert tool pin.
- Reverse disassembly procedures to install a replacement tool. Before installing a new tool, check each part for wear, breakage, scores, etc. Remove burrs and swellings on each tool pin, apply a coat of grease to the movable and frictional areas of the tool pin and tool, and finally install tool. Excessively deformed tool pins will make difficult replacement of tool. Therefore, tool pins are required to be checked every 100 to 150 hours of operation.
- If replacement tool is not a genuine part, we do NOT WARRANTY the performance of other parts of the breaker.

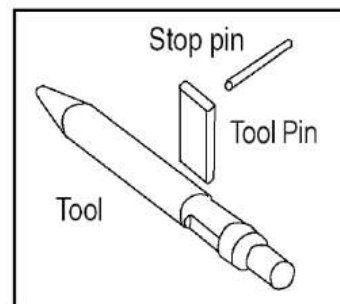
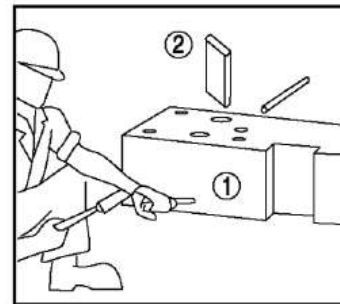

5. BREAKAGE OF TOOL

The service life of various tool depends on the manner of handling them. The tool can sufficiently withstand the vertically acting load, but it is weak to the perpendicularly acting load. Especially, the tool is affected by the negative conditions, such as, force by craning operation, tilted blowing, wrenching, idle strokes, etc. its service life become shorter. There are several ways of breakage of tool. Each cause of breakage can be inferred by observing breakage sections. Further the breakage case which is not caused by low-quality materials or insufficient heat-treatment but by wrong way of handling, which the manufacturer is not responsible for the breakage. (See below figure) The breakage section has the origin on the outer surface, a narrow area of fatigue breakage and a wide area of rough grey area and final breakage part has the share-lip form. Such an undulation on the breakage section and its inclination to the right and left can be proved that the breakage is caused by excessive force which exceeds the toughness of the tool. Such a breakage is supposed to occur owing to careless handling of the tool. To avoid such a breakage, more carefulness and attention are required in handling the breaker.

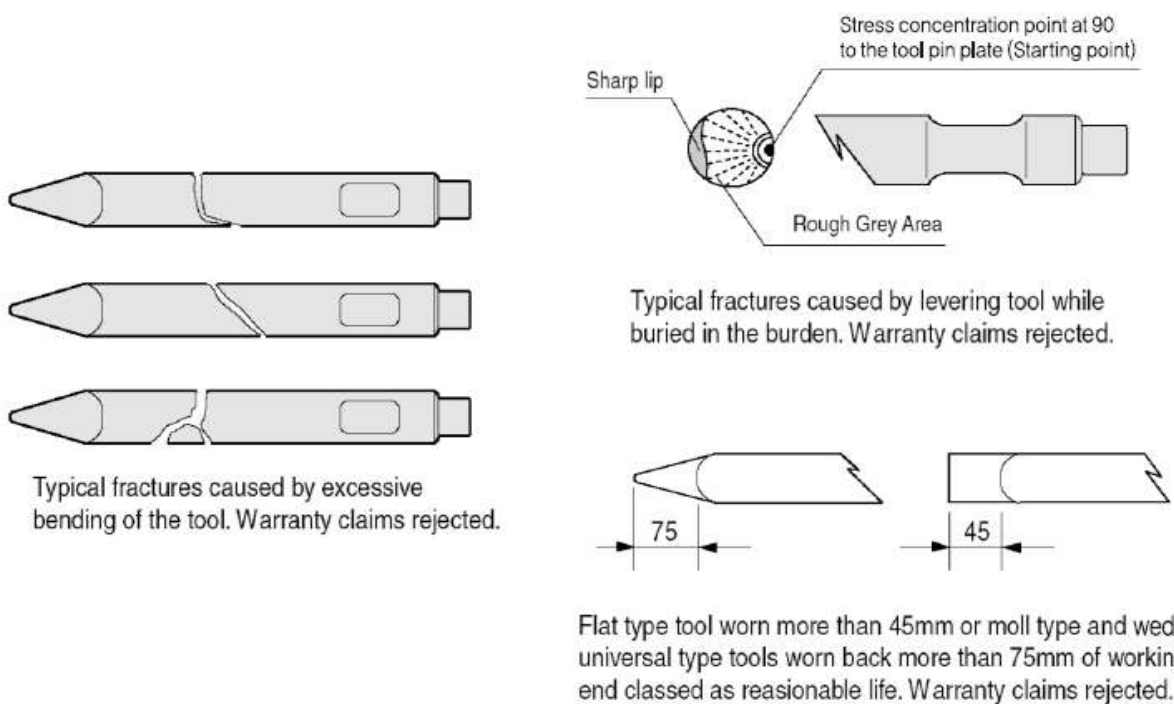

6. DISASSEMBLY AND ASSEMBLY OF BREAKER BODY

Since breaker body is manufactured by state-of-the-art processing techniques and consists of high-quality hydraulic parts, it is dangerous to disassemble breaker at a workshop. Contact our service station when disassembly is called for, otherwise quality and performance of the breaker cannot be guaranteed.

9. *Trouble shooting guide*

1. PROBLEMS IN OPERATION

If the breaker does not work or blow frequency and blow power get worse, check the arranging method. And then inspect according to the following order.

Symptom	Cause	Required action
No blow out	<ol style="list-style-type: none"> Excessive back head gas pressure Stop valve(s) closed Lack of hydraulic oil Wrong adjustment of pressure reducing valve Faulty hydraulic hose connection Oil back head infection 	<ol style="list-style-type: none"> Re-adjust nitrogen gas pressure Open stop valve Fill hydraulic oil Tighten or replace Replace back head o-ring, or cylinder bush step seal
Low impact power	<ol style="list-style-type: none"> Line leakage or blockage Clogged tank return line filter Lack of hydraulic oil Hydraulic oil contamination, or heat deterioration Poor main pump performance Back head nitrogen gas low Low flow rate by mis-adjustment of flow control pressure reduction valve Chisel out of range for blowing position 	<ol style="list-style-type: none"> Check lines Wash filter, or replace Fill hydraulic oil Replace hydraulic oil, rinse tank and replace hydraulic oil inside lines Call an authorized service man Refill nitrogen gas Re-adjust reduction valve Rush down chisel by excavator operation
Irregular impact	<ol style="list-style-type: none"> Low accumulator gas pressure, of bad accumulator Bad piston or valve sliding surface Piston moves down/up to blank blow hammer chamber 	<ol style="list-style-type: none"> Refill nitrogen gas Call an authorized service man. Rush down tool by excavator operation
Bad tool movement	<ol style="list-style-type: none"> Tool diameter incorrect Tool and pin jammed from tool retainer pin wear Jammed lower bush and tool Deformed tool and piston contact area 	<ol style="list-style-type: none"> Replace tool with genuine replacement parts Smoothen rough surface of tool Smoothen rough surface of lower bush interior Replace tool
Sudden reduction power and pressure line vibration	<ol style="list-style-type: none"> Accumulator gas leakage Accumulator diaphragm damage 	<ol style="list-style-type: none"> Replace o-ring, or refill nitrogen gas Replace diaphragm

Symptom	Cause	Required action
Oil leakage between front head and tool	1. Cylinder seal worn	1. Replace seal
Gas leakage	1. O-ring damage in related parts	1. Replace relevant o-ring

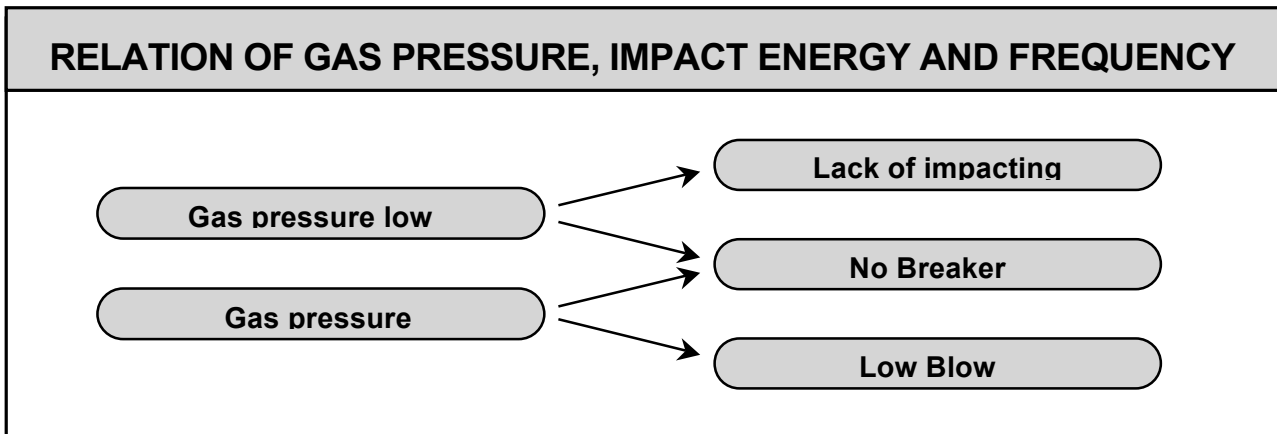



2. GAS LEAKAGE

Trouble	Cause	Remedy
Gas leakage from the top of charging valve	<ul style="list-style-type: none"> ● Defective o-ring in charging valve ● Defective or damaged in charging valve 	<ul style="list-style-type: none"> ● Replace ● Repair or replace charging valve
Gas leakage between charging valve and back head	<ul style="list-style-type: none"> ● Defective o-ring in charging valve ● Charging valve loose in back head 	<ul style="list-style-type: none"> ● Replace ● Re-tighten
Gas leakage between cylinder and back head	<ul style="list-style-type: none"> ● Defective o-ring in back head 	<ul style="list-style-type: none"> ● Replace
Gas leakage from drain plug hole	<ul style="list-style-type: none"> ● Defective gas seal in seal retainer ● Defective step seal in seal retainer ● Seizing of piston and seal retainer 	<ul style="list-style-type: none"> ● Replace ● Replace ● Repair or replace seal retainer and piston.(When repaired replace packing)

3. OIL LEAKAGE

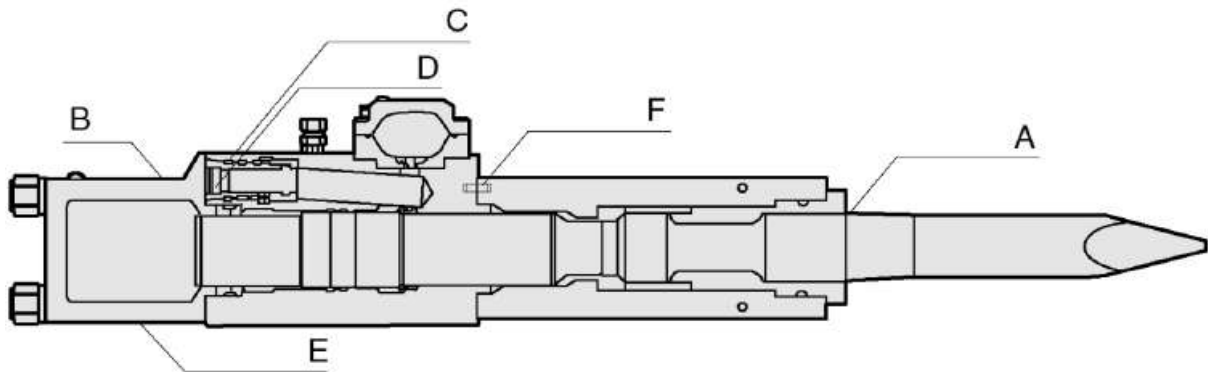
Even if oil is leaking, there is no use to replacing parts at all times. Check the following points listed in the chart below. The user can check the () marked points before calling the dealer.



	Area of oil leakage	Condition	Causes & Remedies
A	Between the tool and lower bush	<ul style="list-style-type: none"> ● A large amount of oil is leaking ● Check if it is coming from oil or grease 	Seals damaged <div style="text-align: center;">REPLACE</div>
B	Surface of breaker	<ul style="list-style-type: none"> ● Oil leaking from the hose & flange adapter portion 	 Loose breaker hoses and bolts <div style="text-align: center;">RETIGHTEN</div>
C	Valve housing bolts & cap bolts	<ul style="list-style-type: none"> ● Oil leakage from reassembly of valve after overhaul 	NORMAL : During assembly from lubrication oil & anti-rust oil applied
D	Between main valve & surface of cylinder	<ul style="list-style-type: none"> ● Oil leakage from reassembly of breaker after overhaul 	NORMAL : - Clean oil - Check that seal is damaged - Loosen bolts - Replace with new seal
E	Between cylinder and back head	<ul style="list-style-type: none"> ● Oil leakage 	 Loose tie rod nuts <div style="text-align: center;">RETIGHTEN</div>
		<ul style="list-style-type: none"> ● Oil leaks again 	<div style="text-align: center;">REPLACE</div> Damaged o-ring
F	Between cylinder and front head	<ul style="list-style-type: none"> ● Oil is leaking 	Loose plugs assembled on the surface of cylinder <div style="text-align: center;">RETIGHTEN</div> Replace damaged seals

10. Maintenance Intervals

NOTICE

- Before hydraulic breaker operation, be sure to check the following points

● Every 3 hours

- Apply the grease in front head.
- Check hydraulic oil temperature. Piping and hose connections, and working condition.
- Check tightness of fasteners.

● Every 10 hours, or Daily

- If rough skin on the tool and tool pins have found, its must be removed.
- Check the nitrogen gas pressure in back head.
- Retighten the bracket bolts.

● Every 50 hours, or Weekly

- Check the clearance between tool and front cover.
- Check hydraulic hoses
- Retighten the through bolts.

● Every 1000 hours, or Six(6) Months

- Factory inspection by authorized service personnel recommended.
- All hydraulic pipe and hose connections.
- Hose interference from carrier movement.
- Conditions of oil filter. accumulator diaphragm, through bolts and tool pins.
- Check top buffer & base buffer. (Box Type)
- Change wearing plate. (Box Type)

● Every 2000 hours, or Annually

- All hydraulic pipe and hose connections.
- Hose interference with excavator boom.
- Conditions of oil filter, accumulator diaphragm and through bolts.
- All seals & Plugs.
- Conditions of piston, front cover, inner bush.
- Change top buffer & base buffer.

11. Moving and lifting



WARNING

Always use eye-bolts when lifting & moving the hydraulic breaker, after fasten up to bracket. Fasten The ropes to the shackles(four pieces) and lift the hydraulic breaker up.
Remove the eye-bolts before hydraulic breaker operation.
The hydraulic system to base machine must be checked by an authorized service engineer before first use and after any modification

12. Storage

When operation is interrupted or after operation

When operation is interrupted or after finishing the work. Move the base on level ground Remove mud from the Hydraulic breaker and set the hydraulic breaker on wood blocks.



CAUTION

- Do not touch the tool when hydraulic breaker just stop to work. Because very hot.

- Check whether oil leaks from hydraulic system and whether the tool is damaged.
- If the hydraulic breaker is operated in river. Dry the hydraulic breaker body and apply the grease to the front head.

When hydraulic breaker is not used for a long time 3 weeks more



CAUTION

- If the following procedures are neglected, the rust is generated in the main body to cause serious Troubles.

- Discharge the nitrogen gas with the back head and accumulator, and then push the piston to avoid rust into the cylinder.
- Assemble the tool and store the hydraulic breaker indoors after applying the grease to every part, especially Internal part, of front head.